

Ghibli R30

7-30 kg / 15-66 lb
Commercial Coffee Roaster



User Safety
Above All
Emission-Free
Ambience

Welcome to Ghibli R30

Coffee-Tech Engineering is proud to present the next generation of drum batch roasters, with our latest launch: Ghibli R30.

We created an advanced roasting machine that allows perfect control over results and cup profiles, by enabling roast masters to predefine their desired calibration preferences.

Ghibli R30 is a beautiful machine with many robust features under the hood. It offers fully- closed fairing protected by its insulated covered-drum housing, and comes complete with smart-thermal sensors and noise-reduction components. The ergonomic design is ambidextrous for both right and left-hand users. This left/right selection option enables users to install and position Ghibli R30 in any desired location, regardless of the existing infrastructure on site.

For the highest roasting efficiency, Ghibli R30 is designed to minimize pollution and reduce gas consumption. It brings into reality our continued research in thermodynamic, airflow routing, precision gas burners, and high-efficiency combustion chambers. Marking a huge step forward in quality roasting, Ghibli R30 delivers superb results, free from roasting defects even for the most stubborn beans. It shows a wonderful smooth ride over the entire batch, and is also suited for rapid roast durations and smaller quantities than a full batch.

Our commitment to the endless pursuit of excellence, ensures the Ghibli R30 drum batch roaster produces boutique-quality coffee that boasts a full aromatic spectrum. It is also well-suited for commercial quantities.

Precision Design

To deliver unmatched power and precision, the Ghibli R30 is based on advanced product design software, extensive lab research, and rigorous testing methodologies. The result is a meticulously designed roaster, which optimizes the entire scope of elements that produce a superior roasting process.

Ghibli R30 comes complete with features that set it apart from the rest:

- Advanced thermodynamic characterization.
- Smart Vortex drum, allowing 90% less air to transform the heating. This improved heat exchange, requiring much less air, efficiently exchanges the heat within the combustion space, while directing it in an accurate spiral flow path along the drum and through the coffee itself, to let the beans reach a full bodied flavor.
- Gas consumption is dramatically low, due to the smaller amounts of secondary air that is required.
- Fully modulated burner, providing precise control with 100% burner power resolution.
- Option for two gas burners.
- Dual positioning option for burner relative to drum bottom part, either to the right beneath the batch for full intensity, or to the left for a milder cup.
- The highest efficiency known in the industry for a gas combustion device, with minimum pollution levels.
- Precision drum housing, to ensure the drum always spins “in line”, with a sturdy design that can bear the load for many years.
- Accurately proportioned drum design, for an optimal ratio of conductive and convective heat.
- In-drum fluidizing paddles, designed to perfectly stir the beans while creating greater heat conduction between the metal and beans, separating the chaff and immediately releasing the beans from the drum into the cooling group.

Perfect Heat Dispersion

As part of the entire Ghibli line, the Ghibli R30 is designed with a closed ceramic combustion chamber surrounding the drum, ensuring heat distribution remains uniform at all times.

Secondary air is allowed to enter by measure, and only through specific ducts positioned at the most crucial points. The heat is exchanged with the cold air on its way to the drum, with maximized efficiency.

Clean, Green, Safe, and Efficient Heating System

The new Vortex drum design dramatically reduces the required intake of the secondary cold air flow. This directly impacts the amount of gas for burning, so that much less is needed to keep the process at optimized temperature ranges. Less gas means lower running cost, fewer impurities and polluting fumes, and minimized energy for smoke treatment with less air and less combustion.

Coffee-Tech’s entire Ghibli line features a highly efficient pre-mix, low NOx gas burner. The Ghibli R30 roaster comes equipped with one-to-two fully modulated burners. It provides a wide range of settings that easily maintain a constant heat.

The roaster’s clean heat source provides maximum gas-burning efficiency, with minimum levels of carbon monoxide emission. Safe for the operator, roastery employees, and the coffee itself, Ghibli R30 is highly cost-effective and stable, featuring many parameters for control and calibration as described in detail in our user manual.

Each machine is tested and calibrated using a combustion gas analyzer, for optimal calibration.

User and Ambient Safety

Coffee-Tech’s entire Ghibli line is constructed similarly to a closed-sealed ceramic combustion chamber.

The combustion chamber is the drum housing itself, which is under negative pressure throughout the process. Sucking the secondary air through specific ducts, it is the only place into which air can penetrate.

Our advanced design ensures the roaster’s surrounding is kept completely pollutant free, with zero gas or odor discharge to the immediate environment. Coffee-Tech Engineering machines are designed for a superior roasting experience of flavor while ensuring top safety.

Fire Hazard Safety Features

Coffee-Tech Engineering roasters, and the Ghibli R30 among them, are featured with an in-drum fire extinguishing faucet that is connected to a live water line.

All our machines are equipped with a manual drum evacuation hand crank. In case of fire, users can perform the procedure single-handedly, as the drum door automatically remains open based on our safety design and advanced mechanism.

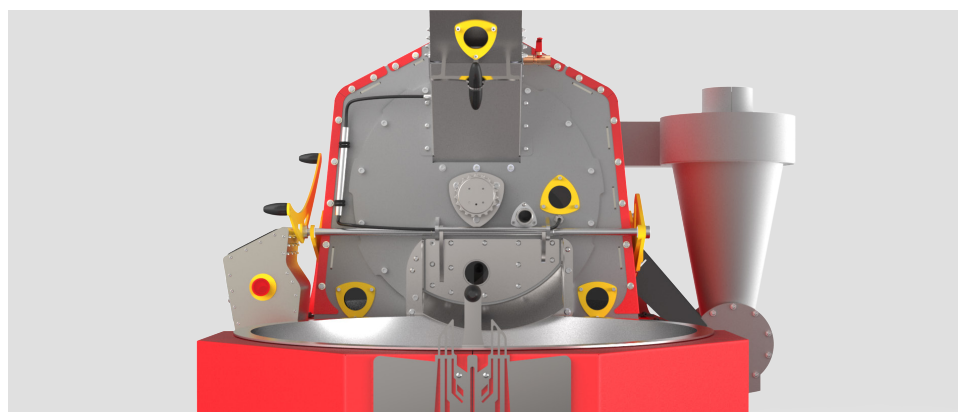

Feature-Rich Offering

Coffee-Tech Engineering is committed to providing the best value in each machine, packed for the full experience. Driven by excellence, we have introduced many new industry standards through our designs.

Our feature-rich offering also includes the following items that directly impact the finished brew:

- To ensure ease of use, we incorporate components that are supplied by leading global manufacturers, including bearings, gear motors, burners, and other electrical elements, alongside our renowned customer support service that caters to each client to the fullest.
- Our Ghibli line is now equipped with a LED-illuminated magnifying glass, for better trier sample viewing that detects tipping even before it occurs.
- Drum door is smoothly operated on oil-free bearings, and has an intricate dead-lock closing mechanism instead of those nasty metal weights.
- Drum gap is easily set by a micrometric regulation hub, even while the machine is in mid-cycle. Trust us, our experience has shown that no one thinks alignment is needed without having it, so we added this highly expensive mechanism to cut support time for the benefit of our users.
- The roaster's main self-aligning bearing hub is sealed, to avoid grease leaking onto the cooling pan.
- A high capacity, high pressure cooling blower provides short batch cooling time, under tough conditions.
- For enhanced visibility, tempered glass lenses encircle the roaster, in the combustion chamber peephole, green hopper window, and drum beans monitoring lens.
- The roaster has a smart drum opening and paddle geometry, for fast drum evacuation.

Roasting Profile and Control Panel

Ghibli R30 is equipped with a touch-screen panel and built-in roasting profiler, exclusively developed by Coffee-Tech Engineering. Users can pre-set and control the roasting process, for either manual or automated mode. It can also integrate into roasting data logging applications and software, using a built-in external USB cable.

- This Profiler enables any user to predefine and program their personal roast profiles. By recording the desired heating curves, any roast profile can be applied time and again, with pinpoint accuracy.
- Ergonomically designed for simple operation and easy maintenance, the control panel features an emergency stop switch, a USB port for computer connection, and an accessory operating platform that includes optional features such as de-stoner and pneumatic loader with individual frequency inverters. Any other optional feature can be added, hassle-free.
- The profiler analyzes the internal temperature at three distinct locations, simultaneously managing the fully modulating burner. In addition, the software also controls the drum speed and airflow within the drum, allowing complete control over the entire process.

Robust-Yet-Simple Chaff Evacuation System (optional)

Ghibli R30 can be ordered with an automatic heavy-duty chaff evacuation system. It continuously empties the chaff into an external bucket, and is designed to ensure no accumulation falls inside the cyclone.

During operation, all that remains is to simply dump the contents of the bucket, at any time. To clear the chaff, there is no need to stop the machine or rush over to it especially at any point during the procedure, since the chaff has already exited the machine.

Chaff Compacting Device (Optional)

For the Ghibli line, a compacting device can be ordered to complete the chaff evacuation system. It packs the chaff into small capsules that can be put away, for later reuse in heating or for agricultural purposes.

Cooling Group

The Ghibli R30 is equipped with a stainless steel cooling group, which has a large stainless steel screen mesh that remains clean and residue-free for life.

Here are some of its benefits:

- No cleaning is required, as it operates a Teflon agitation blade and has a dedicated high-capacity cooling blower. The cooling group also features two cleaning doors.
- The outer stainless steel wall is shielded by machine fairing, to ensure no heat is reflected back onto the user or into their surroundings.
- A collection bucket is supplied for the roasted beans, made by food-grade stainless steel, wheeled, and elegantly styled to complement this lavishly-designed machine, replacing any of those unfitted plastic containers that function as elaborate collectors.

The Next-Gen Vortex TO4 Roasting Drum

In Ghibli R30, airstream blasts in spiral motion into the drum and through the coffee beans, requiring smaller amount of air to enter the roaster for a full effect. The longer spiral path across the drum and through the coffee bed is unlike the olden traditional roaster mechanisms, which had a perforated back plate allowing huge amounts of air into the drum in a short, straight path.

With our roaster, the beans are not stripped away from their coffee goodness, while the energy is also used to maintain the heat right next to the exhaust without working on the coffee itself. This innovative approach ensures a unique added-value offering for cost-effectiveness, energy optimization, and enhanced flavor. Lab tests have already shown a huge improvement in the coffee's solids content and density, with amazing improvements in gas consumption, roasting time, fume emission.

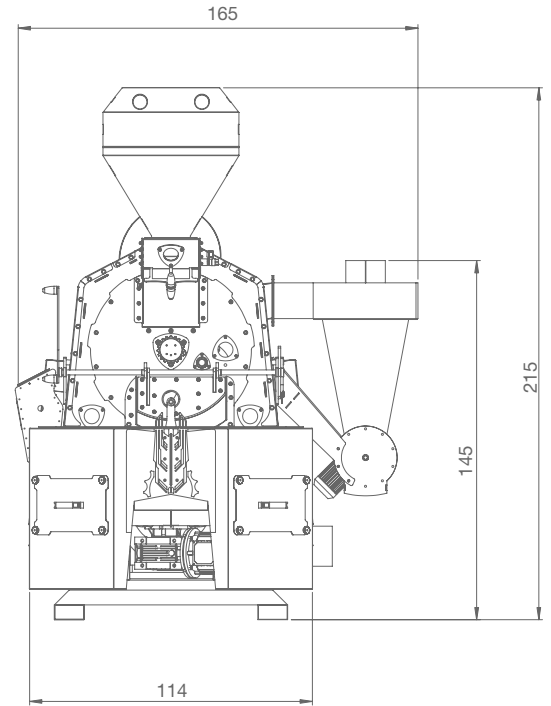
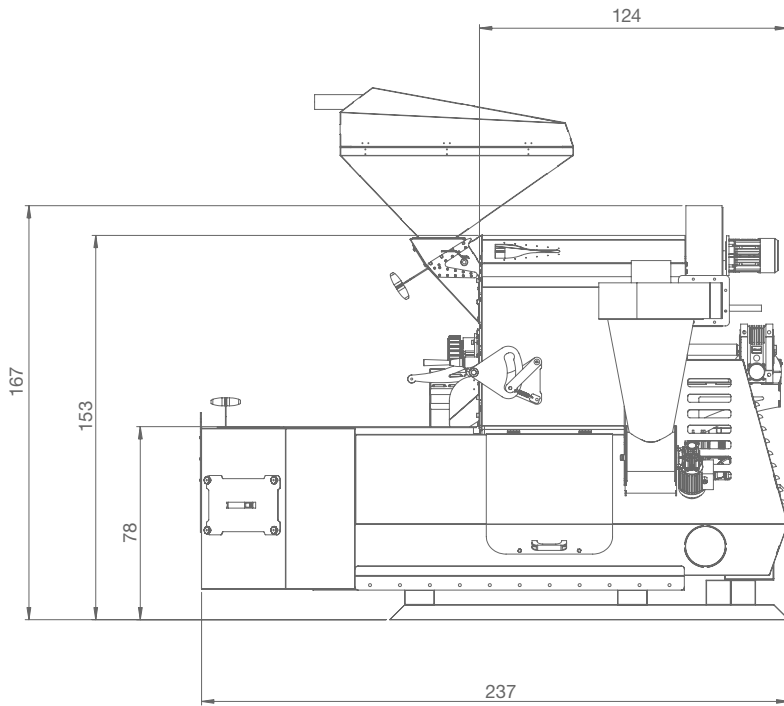

Heating Technology



Conduction



Convection



Indirect Flame
[OPT]

Safety



In Drum
Extinguish



Safety
Manual Crank



Pollution Free
Ambient

Roasting Method



Drum Roasting

Control Features



RDL



Drum Speed
Control



Blower Speed
Control



Multipoint
Temp.



Touch
Screen

Built-in Features



Vortex TO4



Full Modulation
[OPT]



Ceramic
Chamber



Sub-Atmospheric
Combustion Chamber



Infrared
Drum [opt]



Thermodynamic
Drum [OPT]

Sustainability



Low Energy
Consumption



Low NOx

Technical Specifications

Batch Capacity:

7-30 kg / (15-66 lb) of green coffee beans

Roasting Cycle:

±16 minutes up to 4 batches per hour

Quality and safety compliance:

CE, RoHS, EMC

Electrical Specifications:

50/60 Hz. 5000W 380V/230V
3 phases

Heating Method:

Gas: L.P.G. /Natural Gas
(68k - 170k BTU/h) one or two individual burners, fully modulated or single stage.

Drum housing:

Sub atmospheric combustion chamber

Chaff Evacuation:

Cyclone type chaff collector with chaff evacuating device.

Drum Operation:

Direct drive individual heavy-duty gear motor 1.5 hp with frequency inverter for speed control

Cooling Agitation:

Direct drive individual heavy-duty gear motor 1 hp.

Cooling Blower:

High capacity 1 hp cooling blower, cooling time depends on other external conditions.

Safety:

Safety drum discharger
In-drum extinguish

Drum Venting:

High heat individual blower, 0.75hp with frequency inverter for speed control with easy hanging bracket for blower periodical cleaning.

Bearings:

One bearing to grease only, at front, High temperature self-aligned bearing sealed. The front wet bearing uses for drum gap aligning by its micrometric regulation bearing hub. Machine can be provided with suitable greasing pump and one kg of high temperature grease.

Doors Opening:

All machine's door openings are actuated manually, pneumatic operation is optional. Drum gate is hinged with oil free bearings and locking with cam follower state of art mechanism

Body:

Full fairing covered machine structure, Low profile with built in fork lift positioning tunnels. Full precision metal work, top quality materials and hardware, galvanized steel, carbon steel and stainless steel.

Also Available:

Traditional wood/charcoal heating conversion / Automatic software/ pneumatic doors/ single stage burners, one or two.

General Dimensions:

157(w) X 237(d) X 209(h) cm 62(w) X 93(d) X 82(h) inch

Weight:

900 kg (1984 lb)