

Ghibli R15 Wood Fired

3-15 kg / 6.5-33 lb.
Commercial Coffee Roaster



Where technology meets tradition

The Firewood Ghibli R15 utilizes wood combustion for roasting. Roasting occurs by means of convective hot air that flows across the roasting drum, transferring heat and the aroma of the wood to the beans. With this method of roasting, the end result is influenced by the type of wood being used, from natural coals to aromatic chopped fruit-wood or other aromatic types such as oak.

The Firewood Ghibli R15 is one of the most advanced roasters in the industry. The roasting process can be conducted manually by digital temperature control or automatically by the accompanying software. Heat is directed to the drum housing for heating through a pneumatic selector box that features a waste gate connected to the chimney, which can block heat quickly.

The Firewood Ghibli R15 operation is extremely clean and simple, with a highly efficient firing group that consumes a small amount of wood per batch. For example, one batch will only use roughly two pieces of wood, depending on its size.

Using the Firewood Ghibli R15 to roast is much more than just another marketing highlight - it is joyful and, in a way, easier and more intuitive than roasting with gas, as only an organic heating source is being used. This also adds a whole world of flavors to your precious coffee. Wood aroma is the only legitimate addition to the aromatic spectrum of your coffee. Nevertheless, roasting with a neutral flavor is easy - simply use natural coals.

Roasting times with the Firewood are relatively short as a batch of 15kg can be roasted in 11 to 16 minutes. Roasting with the Firewood requires a pressurized air source for the selection box actuator.



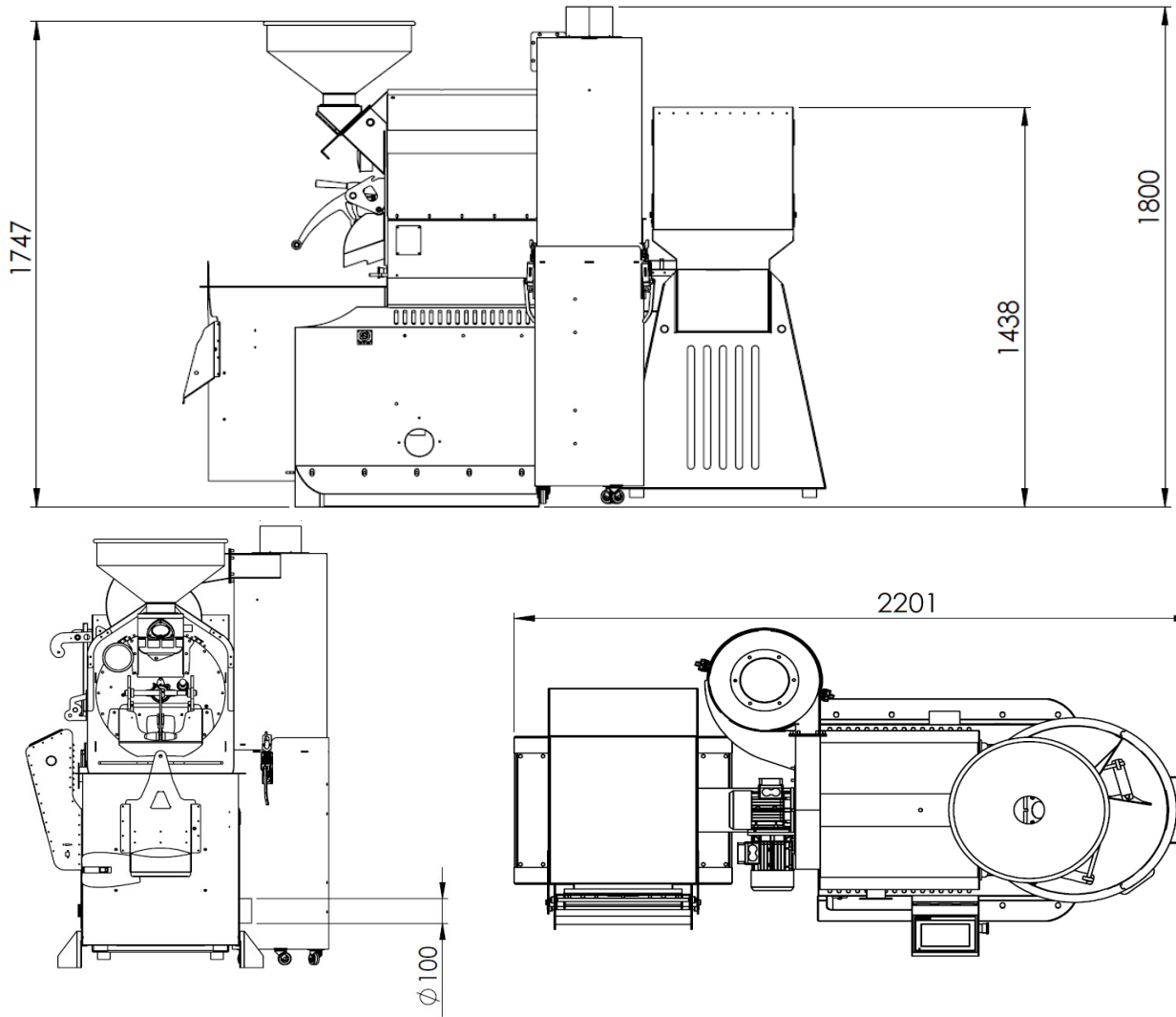

Heating Technology



Conduction



Convection



Indirect Flame



Wood Heating

Safety



In Drum Extinguish



Safety Manual Crank



Pollution Free Ambient

Roasting Method



Drum Roasting



Wood Heating

Control Features



RDL



Drum Speed Control



Blower Speed Control



Multipoint Temp.



Touch Screen

Built-in Features



Automatic (Optional)



Ceramic Chamber



Sub-Atmospheric Combustion Chamber



Infrared Drum

Sustainability



Low Energy Consumption



Low NOx

Technical Specifications

Batch Capacity:

3-15 kg / (6.5-33 lb) of green coffee

Roasting Cycle:

12 minutes ± Up to 4 batches per hour

Quality and safety compliance:

CE, RoHS, EMC

Electrical Specifications:

50/60 Hz. 2500 W 3 phases
230V/380V

Heating Method:

Traditional wood/charcoal heating

Drum housing:

Sub atmospheric combustion chamber

Chaff Evacuation:

Cyclone type chaff collector with booster blower - for clean in-house roasting

Drum Operation:

Direct drive individual heavy-duty gear motor 1/2 hp digital variable drum speed control included

Cooling Agitation:

Direct drive individual heavy-duty gear motor 1/3 hp.

Cooling Blower:

High capacity cooling blower, cooling time is about 1-2 minutes

Drum Venting:

Individual blower 1/3hp digital variable speed control included

Bearings:

Four main bearings, two (F&R) precision dry bearing with zero tolerance for centering the drum and two high temperatures, self-aligned bearings, micrometric drum alignment mechanism

Body:

Full precision metal work, top quality material and hardware, galvanized steel, carbon steel and stainless steel

Safety:

Safety drum discharger
In-drum extinguisher

General Dimensions:

114 (w) X 220 (d) X 180 (h) cm
45(w) X 87(d) X 71(h) inch

Weight:

400 kg (882 lb)

Also Available:

Automatic software